

TurnLine

T-CBN SERIES

www.tungaloy.com

Tungaloy Report No. 510-G

T-CBN SERIES

Useful CBN insert with unique shape,
GNGA type 70° corner angle

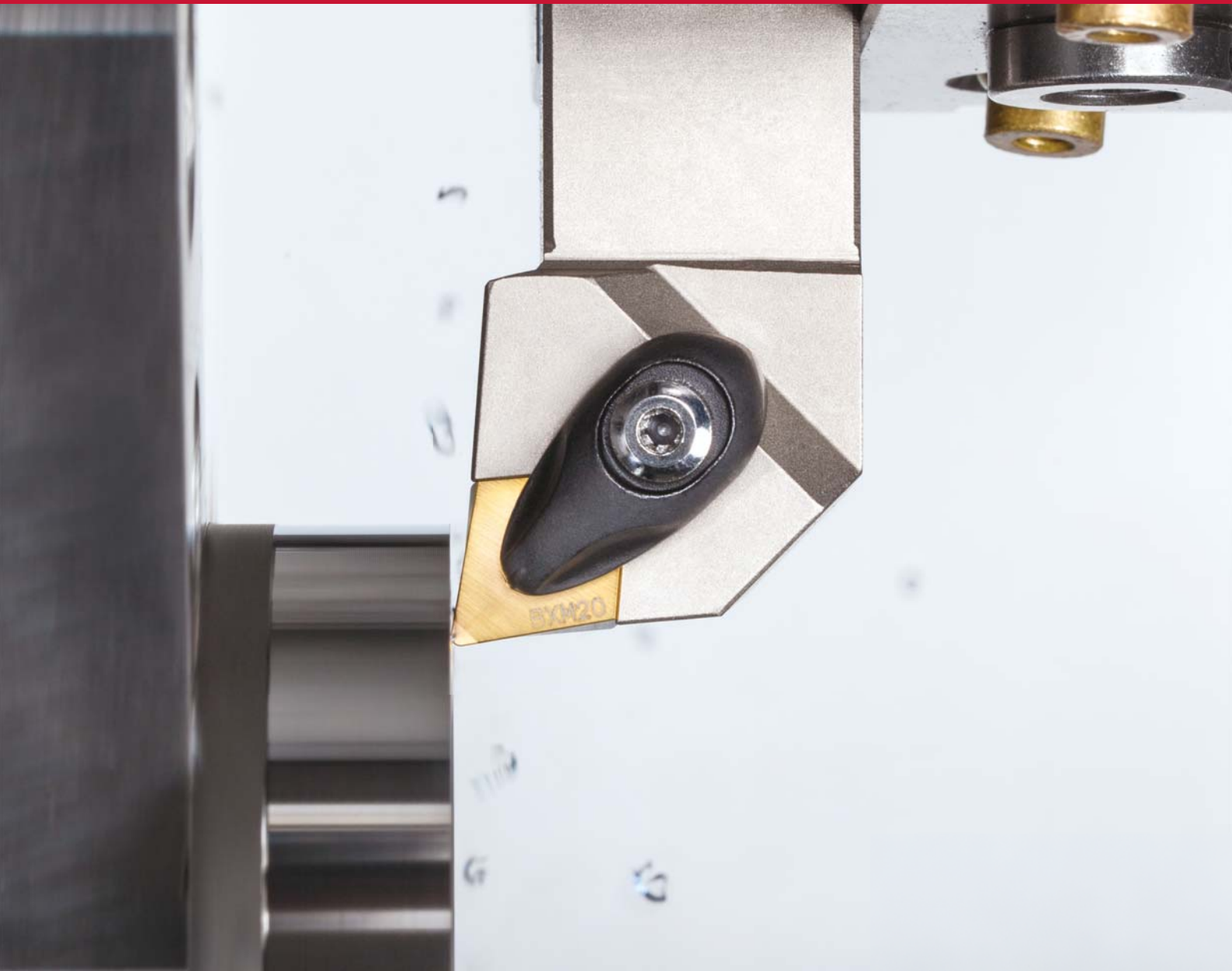



70° GNGA_{type}



80° CNGA_{type}

ACCELERATED MACHINING

TurnLine

T-CBN SERIES

TUNGALOY

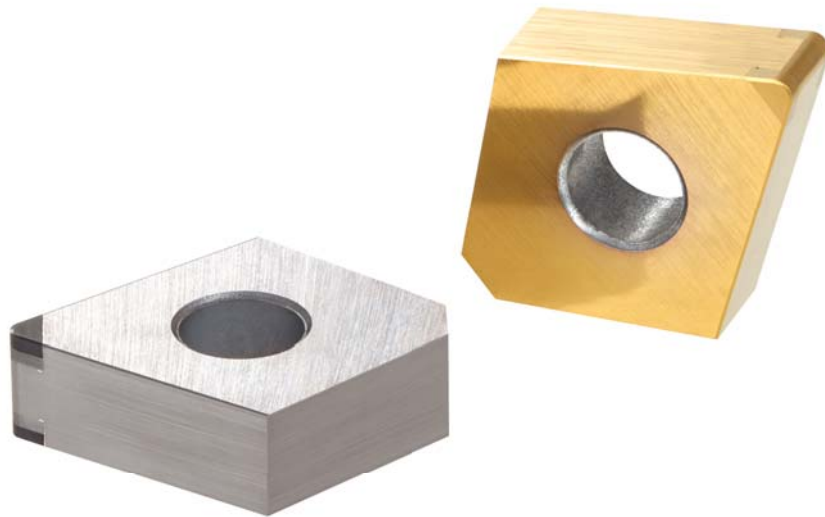

70° corner angle provides high performance
in finishing operation.

For **high efficiency in finishing** hardened steel, cast iron and sintered metals

New shape CBN insert for general turning

- 70° corner angle makes large clearance between insert and workpiece.
- Large clearance reduces the cutting force and wear on edge, and provides smooth chip flow to prevent scratches on machined surface by chips.

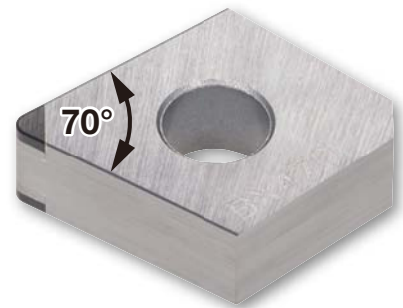

High versatility

- Standard toolholder for ISO CN**1204 insert is available.
- No need offsets compared to CN**1204 insert, due to same geometry of cutting edge position.
- Double sided insert with 2 cutting edges.
- 4 types of CBN grades are available for machining of a wide range of materials.



CUTTING PERFORMANCE

Cutting force (Thrust force)

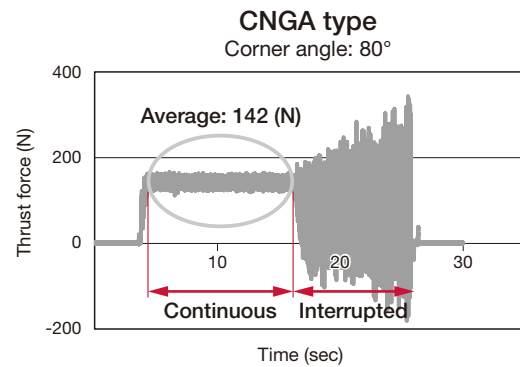
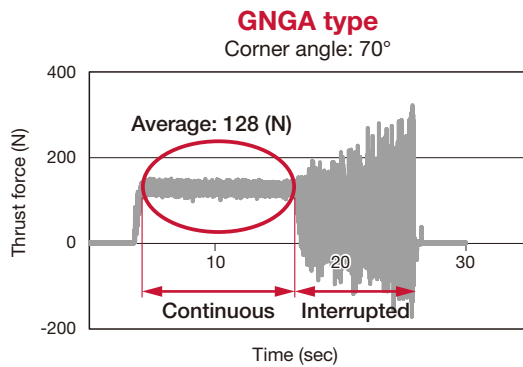

Cutting force of GNGA insert is lower than regular CNGA insert's.

H	Toolholder	: ACLNL2525M12-A
	Insert	: 2QP-GNGA120408 BXM20 2QP-CNGA120408 BXM20
	Workpiece material	: SCM420 / 18CrMo4 (59HRC)
	Cutting speed	: $V_c = 150$ m/min
	Feed	: $f = 0.15$ mm/rev
	Depth of cut	: $a_p = 0.125$ mm
	Machining	: Face turning
	Coolant	: Dry

Chip flow and control in face turning

Chip flow of continuous face turning

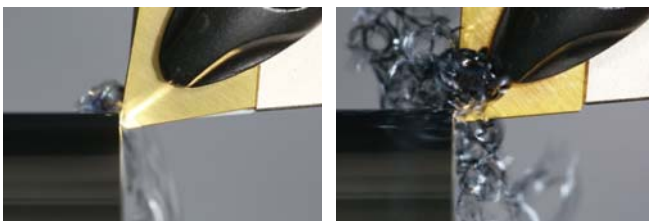

GNGA type
Corner angle: 70°

CNGA type
Corner angle: 80°

Chip control in interrupted face turning



GNGA type
Corner angle: 70°

CNGA type
Corner angle: 80°

Since GNGA type inserts have enough space for chip flow, chip packing doesn't occur, improving surface finish and preventing sudden chipping on cutting edge.

H	Toolholder	: ACLNL2525M12-A
	Insert	: 2QP-GNGA120408 BXM20 2QP-CNGA120408 BXM20
	Workpiece material	: SCM420 / 18CrMo4 (60HRC)
	Cutting speed	: $V_c = 150$ m/min
	Feed	: $f = 0.10$ mm/rev
	Depth of cut	: $a_p = 0.125$ mm
	Machining	: Face turning
	Coolant	: Dry

T-CBN SERIES

TUNGALOY

Negative relief ang., G class,
80° rhombic CBN insert with corner angle 70°.

INSERT

2QP-GNGA

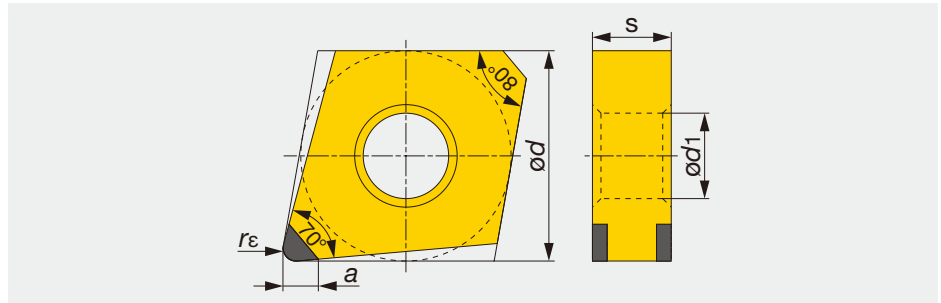
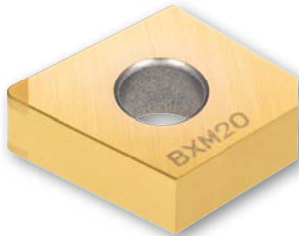

Rhombic, 70°



Designation	Stocked grades				I.C.dia ϕd	Thick- ness s	Hole dia $\phi d1$	Corner radius $r\epsilon$	CBN Length a
	Coated	Non-coated							
	BXM20	BX360	BX470	BX930					
2QP-GNGA120404	✓	✓			12.7	4.76	5.16	0.4	2.3
2QP-GNGA120408	✓	✓	✓	✓	12.7	4.76	5.16	0.8	2.2
2QP-GNGA120412	✓	✓	✓	✓	12.7	4.76	5.16	1.2	2.4

✓ : Stocked items

STANDARD CUTTING CONDITIONS

ISO	Workpiece materials	Grade	Cutting speed V_c (m/min)	Depth of cut a_p (mm)	Feed f (mm/rev)
K	Grey cast iron	BX930 BX470	300 - 1200	0.05 - 0.50	0.05 - 0.30
	Ductile cast iron	BX930	100 - 500	0.05 - 0.50	0.05 - 0.30
H	Hardened steel	BXM20	70 - 220	0.05 - 0.30	0.05 - 0.25
	Sintered metal	BX470	80 - 300	0.05 - 0.50	0.05 - 0.25

PRACTICAL EXAMPLES

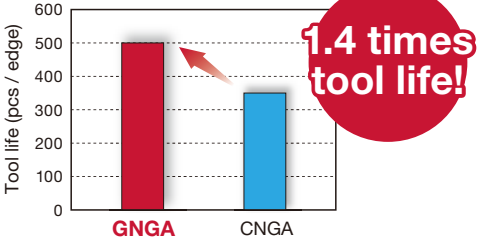
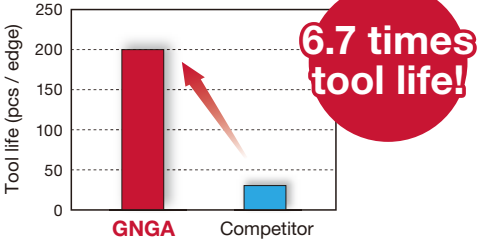
Workpiece type		Flywheel	Collet
Toolholder		DCLNR2525M12	A25R-ACLNR12-D320
Insert		2QP-GNGA120408	2QP-GNGA120408
Grade		BX470	BXM20
Workpiece material		FC250 / 250	SNCM220 / 20NiCrMo2
		 K	 H
Cutting conditions	Cutting speed: V_c (m/min)	500	70
	Feed : f (mm/rev)	0.10	0.06
	Depth of cut : a_p (mm)	0.20	0.20
	Machining	Face turning	Internal turning
	Coolant	External supply	Dry
Results		 <p>1.4 times tool life!</p> <p>Changing the insert from CNGA to GNGA drastically reduces the flank wear behind the corner, improving the tool life 1.4 times longer.</p>	 <p>6.7 times tool life!</p> <p>Competitor's posi-insert has chipping in short number of machining. CNGA type insert doesn't work because of huge burr. GNGA type insert achieves 6.7 times longer tool life without chipping or burr.</p>

Tungaloy Corporation (Head office)

11-1 Yoshima-Kogyodanchi
Iwaki-city, Fukushima, 970-1144 Japan
Phone: +81-246-36-8501
Fax: +81-246-36-8542
www.tungaloy.co.jp

Tungaloy America, Inc.

3726 N Ventura Drive
Arlington Heights, IL 60004, U.S.A.
Phone: +1-888-554-8394
Fax: +1-888-554-8392
www.tungaloyamerica.com

Tungaloy Canada

432 Elgin St. Unit 3
Brantford, Ontario N3S 7P7, Canada
Phone: +1-519-758-5779
Fax: +1-519-758-5791
www.tungaloy.co.jp/ca

Tungaloy de Mexico S.A.

C Los Arellano 113,
Parque Industrial Siglo XXI
Aguascalientes, AGS, Mexico 20290
Phone: +52-449-929-5410
Fax: +52-449-929-5411
www.tungaloy.co.jp/mx

Tungaloy do Brasil Ltda.

Rua dos Sabias N.104
13280-000 Vinhedo, São Paulo, Brazil
Phone: +55-19-38262757
Fax: +55-19-38262757
www.tungaloy.com/br

Tungaloy Germany GmbH

An der Alten Ziegelei 1
D-40789 Monheim, Germany
Phone: +49-2173-90420-0
Fax: +49-2173-90420-19
www.tungaloy.de

Tungaloy France S.A.S.

ZA Courtaboeuf - Le Rio
1 rue de la Terre de feu
F-91952 Courtaboeuf Cedex, France
Phone: +33-1-6486-4300
Fax: +33-1-6907-7817
www.tungaloy.fr

Tungaloy Italia S.r.l.

Via E. Andolfato 10
I-20126 Milano, Italy
Phone: +39-02-252012-1
Fax: +39-02-252012-65
www.tungaloy.it

Tungaloy Czech s.r.o.

Turanka 115
CZ-627 00 Brno, Czech Republic
Phone: +420-532 123 391
Fax: +420-532 123 392
www.tungaloy.cz

Tungaloy Ibérica S.L.

C/Miquel Servet, 43B, Nau 7
Pol. Ind. Bufalvent
ES-08243 Manresa (BCN), Spain
Phone: +34 93 113 1360
Fax: +34 93 876 2798
www.tungaloy.es

Tungaloy Scandinavia AB

S:t Lars Väg 42A
SE-22270 Lund, Sweden
Phone: +46-462119200
Fax: +46-462119207
www.tungaloy.se

Tungaloy Rus, LLC

36-D Harkovsky Lane
308009 Belgorod, Russia
Phone: +7 4722 24 00 07
Fax: +7 4722 24 00 08
www.tungaloy.co.jp/ru

Tungaloy East LLC

Stachek str., h.4, office 2, Ekaterinburg,
620017, Russia
Phone: +7-343-389-13-22
Fax: +7-343-278-94-35
www.tungaloy.co.jp/ru

Tungaloy Polska Sp. z o.o.

ul. Genewska 24
03-963 Warszawa, Poland
Phone: +48-22-617-0890
Fax: +48-22-617-0890
www.tungaloy.co.jp/pl

Tungaloy U.K. Ltd

The Technology Centre,
Wolverhampton Science Park
Glaisher Drive, Wolverhampton
West Midlands WV10 9RU, UK
Phone: +44 121 4000 231
Fax: +44 121 270 9694
www.tungaloy.co.jp/uk
salesinfo@tungaloyuk.co.uk

Tungaloy Hungary Kft

Erzsébet királyné útja 125
H-1142 Budapest, Hungary
Phone: +36 1 781-6846
Fax: +36 1 781-6866
www.tungaloy.co.jp/hu
info@tungaloytools.hu

Tungaloy Turkey

Dudullu, OSB 4. Cad No:4
34776 Umraniye Istanbul, TURKEY
Phone: +90 216 540 04 67
Fax: +90 216 540 04 87
www.tungaloy.com.tr
info@tungaloy.com.tr

Tungaloy Benelux b.v.

Tjalk 70
NL-2411 NZ Bodegraven, Netherlands
Phone: +31 172 630 420
Fax: +31 172 630 429
www.tungaloy-benelux.com

Tungaloy Croatia

Josipa Kozarca 4
10432 Bregana, Croatia
Phone: +385 1 3326 604
Fax: +385 1 3327 683
www.tungaloy.hr

Tungaloy Cutting Tool (Shanghai) Co., Ltd.

Rm No 401 No.88 Zhabei
Jiangchang No.3 Rd
Shanghai 200436, China
Phone: +86-21-3632-1880
Fax: +86-21-3621-1918
www.tungaloy.co.jp/tots

Tungaloy Cutting Tool (Thailand) Co., Ltd.

Interlink tower 4th Fl.
1858/5-7 Bangna-Trad Road
km.5 Bangna, Bangna, Bangkok 10260
Thailand
Phone: +66-2-751-5711
Fax: +66-2-751-5715
www.tungaloy.co.th

Tungaloy Singapore (Pte.), Ltd.

62 Ubi Road 1, #06-11 Oxley BizHub 2
Singapore 408734
Phone: +65-6391-1833
Fax: +65-6299-4557
www.tungaloy.co.jp/tspl

Tungaloy Vietnam

Unit 18, 4th Fl. Saigon Centre Building
65 Le Loi Blvd.
Dist 1, Ho Chi Minh City, Vietnam
Phone: +84-8-3827-0201
Fax: +84-8-3827-0203
www.tungaloy.co.jp/tspl

Tungaloy India Pvt. Ltd.

Indiabulls Finance Centre,
Unit # 902-A, 9th Floor,
Tower 1, Senapati Bapat Marg,
Elphinstone Road (West),
Mumbai-400013, India
Phone: +91-22-6124-8804
Fax: +91-22-6124-8899
www.tungaloy.co.jp/in

Tungaloy Korea Co., Ltd

#1312, Byucksan Digital Valley 5-cha
Beotkkot-ro 244, Geumcheon-gu
153-788 Seoul, Korea
Phone: +82-2-2621-6161
Fax: +82-2-6393-8952
www.tungaloy.co.jp/kr

Tungaloy Malaysia Sdn Bhd

50 K-2, Kelana Mall, Jalan SS6/14
Kelana Jaya, 47301
Petaling Jaya, Selangor Darul Ehsan
Malaysia
Phone: +603-7805-3222
Fax: +603-7804-8563
www.tungaloy.co.jp/my

Tungaloy Australia Pty Ltd

PO Box 2232, Rowville,
Victoria 3178, Australia
Phone: +61-3-9755-8147
Fax: +61-3-9755-6070
www.tungaloy.com.au

PT. Tungaloy Indonesia

Kompleks Grand Wisata Block AA-10 No.3-5
Cibitung
Bekasi 17510, Indonesia
Phone: +62-21-8261-5808
Fax: +62-21-8261-5809
www.tungaloy.co.jp/id



www.tungaloy.com

follow us at:

facebook.com/tungaloyjapan

twitter.com/tungaloyjapan

To see this product in action visit:

Tung-TV

www.youtube.com/tungaloycorporation

Distributed by:



DOWNLOAD
Dr. Carbide App



Available on the
App Store



GET IT ON
Google play



ISO 9001 Certified
QC00J0056
Tungaloy Corporation
18/10/1996

ISO 14001 Certified
EC97J1123
Tungaloy Group
Japan site and Asian
production site
26/11/1997