

DrillLine



**DRILLMEISTER**

[www.tungaloy.com](http://www.tungaloy.com)

Tungaloy Report No. 412S2-G

Irregular surface drilling made easy with  
**new flat-edged DMF drill head -  $\varnothing$ 10 - 19.8 mm**

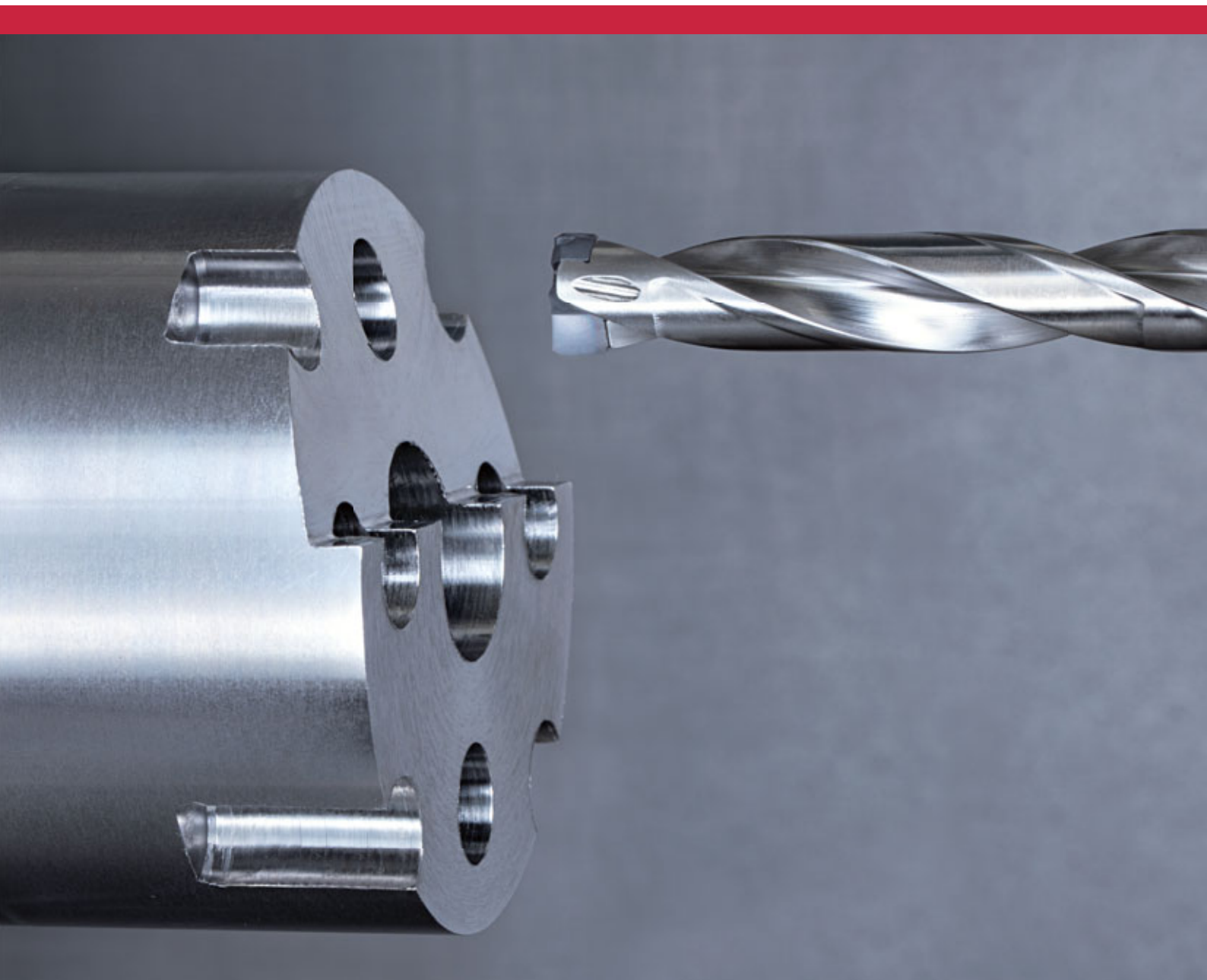

**INDUSTRY 4.0**  
*FEED the SPEED!*



## Optimized edge design for efficient drilling of flat-bottom holes

**New**

### **DMF** DrillMeister flat head

- Flat edge design with pilot edge performs balanced drill entry
- Significantly reduced radial forces promise stable drilling for complex surfaces at drill entry and exit
- Stable drilling with long overhang up to  $L/D = 8$  without pre-hole

**180° flat cutting edges** produces holes with flat bottom. Ideal for counterboring for bolt heads.

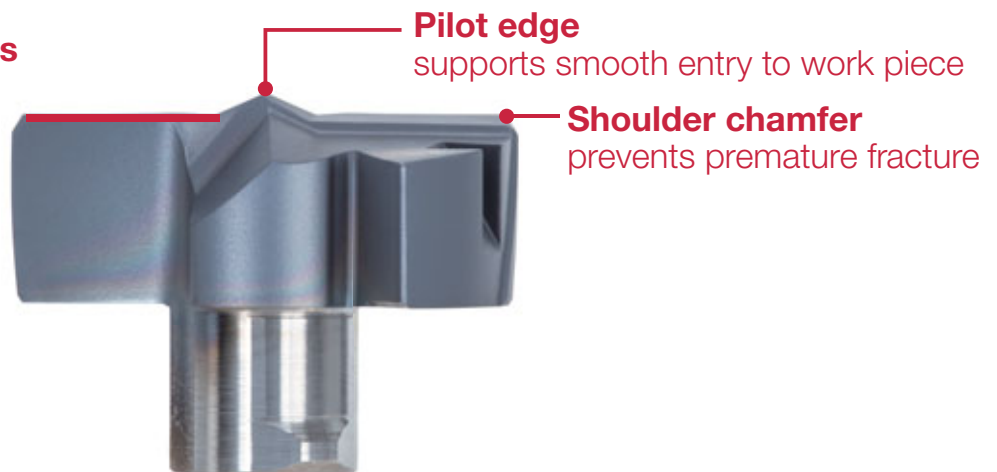
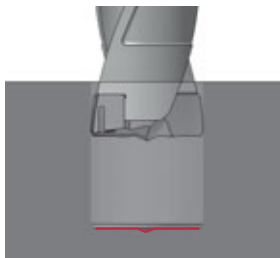

## Solution for a wide application range of complex surfaces:



## DRILL HEAD LINEUP

### DMF Flat geometry head

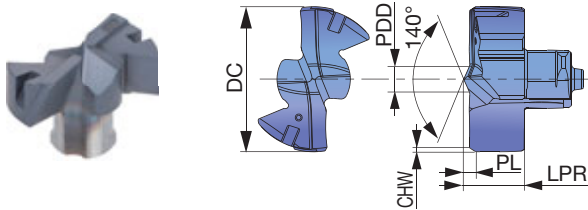

<b>Tool diameter</b>	ø10 - ø17.9	ø18 - ø19.8
<b>Head diameter tolerance</b>	+0.018 / 0	+0.021 / 0

Designation	DC	Grade AH9130	PDD	LPR	PL	CHW	Pocket size	Body
DMF100	10	●	2.89	4.72	1.17	0.4	10	TID*100*
DMF101	10.1	●	2.89	4.72	1.17	0.4	10	TID*100*
DMF103	10.3	●	2.89	4.72	1.17	0.4	10	TID*100*
DMF104	10.4	●	2.89	4.72	1.17	0.4	10	TID*100*
DMF105	10.5	●	2.89	4.72	1.17	0.4	10	TID*105*
DMF106	10.6	●	2.89	4.72	1.17	0.4	10	TID*105*
DMF107	10.7	●	2.89	4.72	1.17	0.4	10	TID*105*
DMF108	10.8	●	2.89	4.72	1.17	0.4	10	TID*105*
DMF110	11	●	2.98	4.90	1.25	0.4	11	TID*110*
DMF115	11.5	●	2.98	4.90	1.25	0.4	11	TID*115*
DMF117	11.7	●	2.98	4.90	1.25	0.4	11	TID*115*
DMF120	12	●	3.13	5.21	1.26	0.4	12	TID*120*
DMF121	12.1	●	3.13	5.21	1.26	0.4	12	TID*120*
DMF122	12.2	●	3.13	5.21	1.26	0.4	12	TID*120*
DMF123	12.3	●	3.13	5.21	1.26	0.4	12	TID*120*
DMF124	12.4	●	3.13	5.21	1.26	0.4	12	TID*120*
DMF125	12.5	●	3.13	5.21	1.26	0.4	12	TID*125*
DMF126	12.6	●	3.13	5.21	1.26	0.4	12	TID*125*
DMF127	12.7	●	3.13	5.21	1.26	0.4	12	TID*125*
DMF130	13	●	3.52	5.53	1.28	0.4	13	TID*130*
DMF131	13.1	●	3.52	5.53	1.28	0.4	13	TID*130*
DMF133	13.3	●	3.52	5.53	1.28	0.4	13	TID*130*
DMF135	13.5	●	3.52	5.53	1.28	0.4	13	TID*135*
DMF137	13.7	●	3.52	5.53	1.28	0.4	13	TID*135*
DMF138	13.8	●	3.52	5.53	1.28	0.4	13	TID*135*
DMF139	13.9	●	3.52	5.53	1.28	0.4	13	TID*135*
DMF140	14	●	3.81	5.96	1.31	0.4	14	TID*140*
DMF141	14.1	●	3.81	5.96	1.31	0.4	14	TID*140*
DMF142	14.2	●	3.81	5.96	1.31	0.4	14	TID*140*
DMF143	14.3	●	3.81	5.96	1.31	0.4	14	TID*140*
DMF144	14.4	●	3.81	5.96	1.31	0.4	14	TID*140*
DMF145	14.5	●	3.81	5.96	1.31	0.4	14	TID*145*
DMF150	15	●	4.24	6.43	1.35	0.4	15	TID*150*
DMF152	15.2	●	4.24	6.43	1.35	0.4	15	TID*150*
DMF155	15.5	●	4.24	6.43	1.35	0.4	15	TID*150*
DMF157	15.7	●	4.24	6.43	1.35	0.4	15	TID*150*
DMF158	15.8	●	4.24	6.43	1.35	0.4	15	TID*150*
DMF160	16	●	4.06	6.84	1.39	0.4	16	TID*160*
DMF161	16.1	●	4.06	6.84	1.39	0.4	16	TID*160*
DMF165	16.5	●	4.06	6.84	1.39	0.4	16	TID*160*
DMF167	16.7	●	4.06	6.84	1.39	0.4	16	TID*160*

Designation	DC	Grade AH9130	PDD	LPR	PL	CHW	Pocket size	Body
DMF170	17	●	4.14	7.15	1.4	0.4	17	TID*170*
DMF175	17.5	●	4.14	7.15	1.4	0.4	17	TID*170*
DMF179	17.9	●	4.14	7.15	1.4	0.4	17	TID*170*
DMF180	18	●	4.16	7.45	1.42	0.4	18	TID*180*
DMF185	18.5	●	4.16	7.45	1.42	0.4	18	TID*180*
DMF190	19	●	4.25	7.79	1.44	0.4	19	TID*190*
DMF195	19.5	●	4.25	7.79	1.44	0.4	19	TID*190*
DMF198	19.8	●	4.25	7.79	1.44	0.4	19	TID*190*

●: Line up

### Recommended dimensions for metric bolt heads

Screw size	M6	M8	M10
øD (mm)	11	14	17.5
H (mm)	6.5	8.6	10.8
ød (mm)	6	9	11
Head	DMF110	DMF140	DMF175
Tool	TID*110...	TID*140...	TID*170...

## STANDARD CUTTING CONDITIONS









ISO	Workpiece materials	Cutting speed Vc (m/min)	Feed: f (mm/rev)			
			DC (mm)			
			ø10 - ø11.9	ø12 - ø13.9	ø14 - ø15.9	ø16 - ø19.8
<b>P</b>	Low carbon steel (C < 0.3) (SS400 / St42-1, SM490 / St52-3, S25C / C25, etc.)	80 - 140	0.15 - 0.28	0.18 - 0.3	0.2 - 0.35	0.25 - 0.45
	High carbon steel (C > 0.3) (S45C / C45, S55C / C55, etc.)	70 - 120	0.15 - 0.28	0.18 - 0.3	0.2 - 0.35	0.25 - 0.45
	Low alloy steel (SCM415, etc.)	70 - 120	0.14 - 0.28	0.16 - 0.32	0.18 - 0.35	0.23 - 0.4
	Alloy steel (SCM440 / 42CrMo4, SCr420 / 20Cr4, etc.)	40 - 90	0.14 - 0.28	0.16 - 0.32	0.18 - 0.35	0.23 - 0.4
<b>M</b>	Stainless steel (SUS304 / X5CrNi18-9, SUS316 / X5CrNiMo17-12-2, etc.)	30 - 70	0.12 - 0.18	0.14 - 0.2	0.16 - 0.24	0.16 - 0.26
<b>K</b>	Grey cast iron (FC250 / GG25, etc.)	80 - 180	0.2 - 0.35	0.25 - 0.4	0.3 - 0.45	0.35 - 0.55
	Ductile cast iron (FCD700 / GGG70, etc.)	80 - 140	0.2 - 0.35	0.25 - 0.4	0.3 - 0.45	0.35 - 0.55
<b>N</b>	Aluminium alloys (ADC12, etc.)	80 - 220	0.25 - 0.4	0.3 - 0.45	0.35 - 0.5	0.4 - 0.6
<b>S</b>	Titanium alloys (Ti-6Al-4V, etc.)	20 - 50	0.08 - 0.15	0.1 - 0.18	0.12 - 0.2	0.14 - 0.22
	Nickel-based alloys	20 - 50	0.08 - 0.13	0.1 - 0.15	0.12 - 0.18	0.12 - 0.22
<b>H</b>	Hardened steel	20 - 50	0.08 - 0.15	0.1 - 0.18	0.12 - 0.2	0.14 - 0.22

- Cutting conditions in the above table show standard cutting conditions.  
- Cutting conditions may change due to the rigidity and power of the machine and the workpiece material.

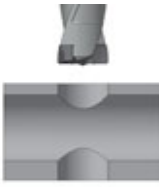
- Machined hole diameter may change depending upon the rigidity of the machine tool or cutting conditions.  
- In case of L/D = 8 & 12 drill, the recommended range of cutting speeds and feeds is between the minimum and median values listed above.









## Application range and recommended tool lengths

Please use the shortest possible tool

Recommended L/D	≤ 8			
Application	Plane surface	Complex exit	Cross hole	Rough / cast surface
				
Recommended L/D	≤ 3		≤ 1.5	
Application	Slant surface	Round surface	Hole expansion	Plunging
				

- Maximum slant angle 12 degrees
- Feed rate should be decreased when drilling uneven surfaces
- Overlap should be under 30% of head dia. at hole expansion
- Plunging width should be 70% of head dia.

## Head combinations of pre-hole to main hole

		Pre-hole		
		DMP	DMC	DMF
Hole	DMP	<b>Good</b> 	<b>Not good</b> 	<b>Not good</b> 
	DMC	<b>Good</b> 	<b>Good</b> 	<b>Good</b> 
	DMF	<b>Not good</b> 	<b>Not good</b> 	<b>Good</b> 

# MEMO

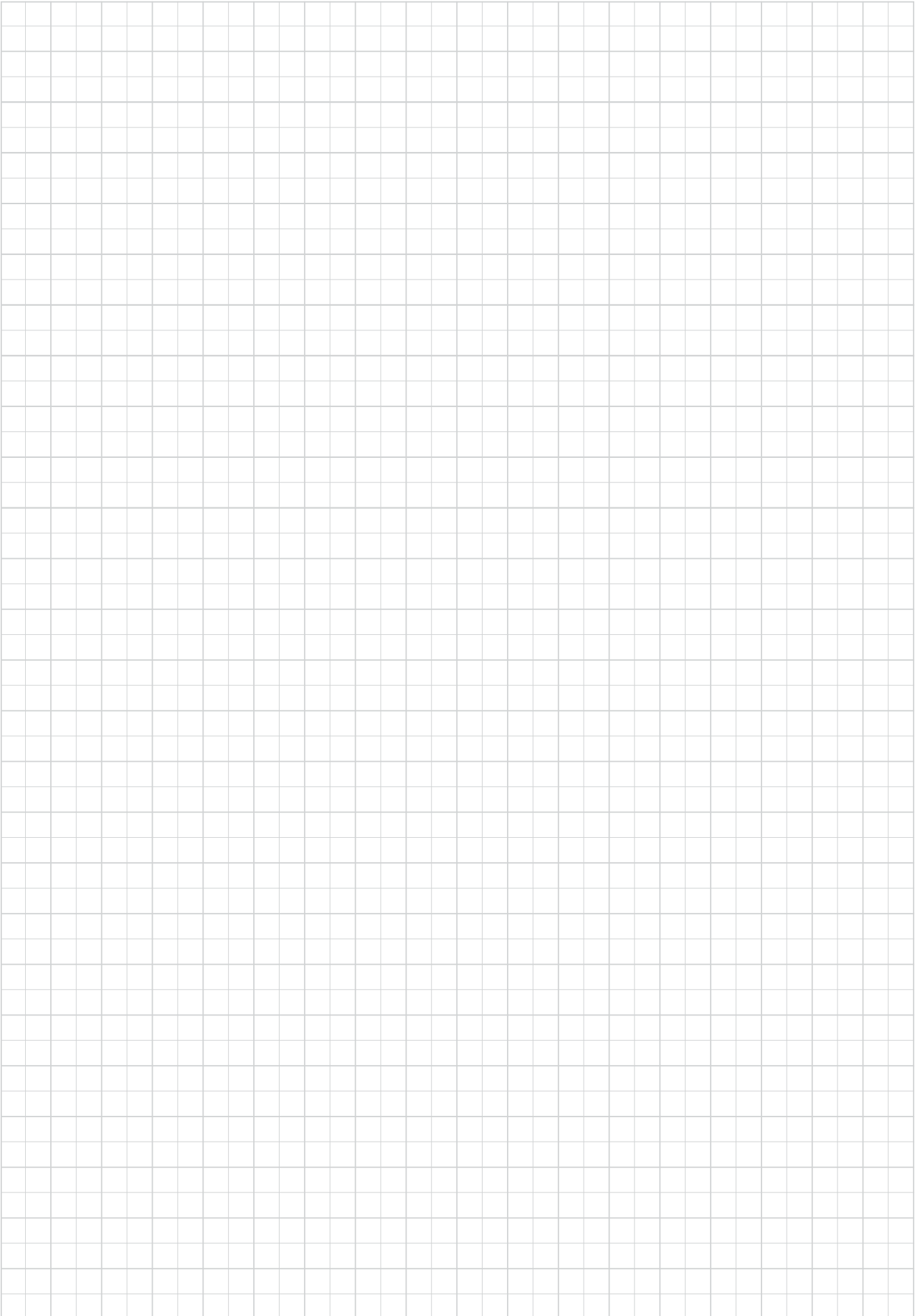

# MEMO

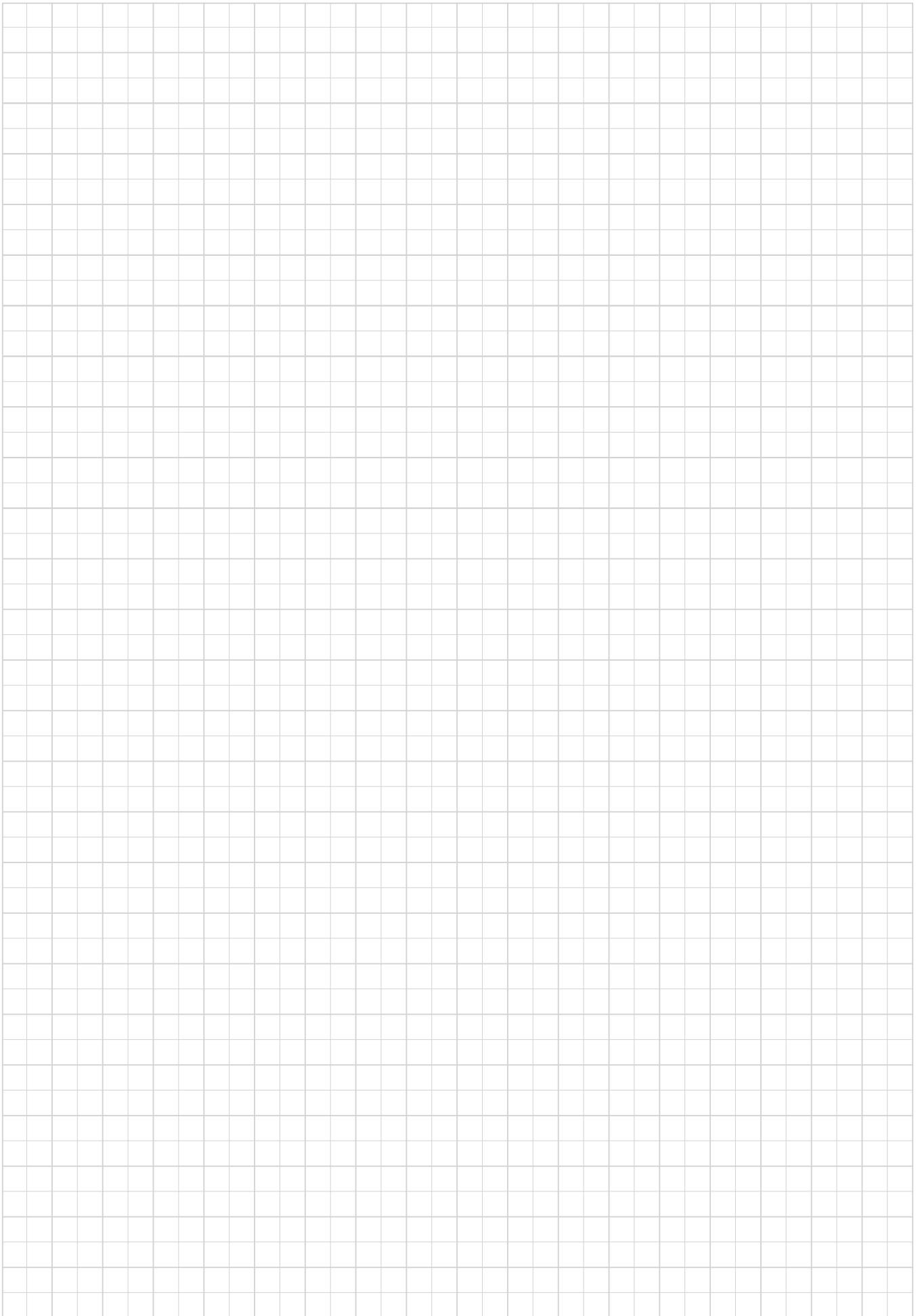

### Tungaloy Corporation (Head office)

11-1 Yoshima-Kogyodanchi  
Iwaki-city, Fukushima 970-1144 Japan  
Phone: +81-246-36-8501  
Fax: +81-246-36-8542  
www.tungaloy.co.jp

### Tungaloy America, Inc.

3726 N Ventura Drive  
Arlington Heights, IL 60004, U.S.A.  
Phone: +1-888-554-8394  
Fax: +1-888-554-8392  
www.tungaloy.com/us

### Tungaloy Canada

432 Elgin St. Unit 3  
Brantford, Ontario N3S 7P7, Canada  
Phone: +1-519-758-5779  
Fax: +1-519-758-5791  
www.tungaloy.com/ca

### Tungaloy de Mexico S.A.

C Los Arellano 113,  
Parque Industrial Siglo XXI  
Aguascalientes, AGS, Mexico 20290  
Phone: +52-449-929-5410  
Fax: +52-449-929-5411  
www.tungaloy.com/mx

### Tungaloy do Brasil Ltda.

Avd. Independencia N4158 Residencial Flora  
13280-000 Vinhedo, São Paulo, Brasil  
Phone: +55-19-38262757  
Fax: +55-19-38262757  
www.tungaloy.com/br

### Tungaloy Germany GmbH

An der Alten Ziegelei 1  
D-40789 Monheim, Germany  
Phone: +49-2173-90420-0  
Fax: +49-2173-90420-19  
www.tungaloy.com/de

### Tungaloy France S.A.S.

ZA Courtaboeuf - Le Rio  
1 rue de la Terre de feu  
F-91952 Courtaboeuf Cedex, France  
Phone: +33-1-6486-4300  
Fax: +33-1-6907-7817  
www.tungaloy.com/fr

### Tungaloy Italia S.r.l.

Via E. Andolfato 10  
I-20126 Milano, Italy  
Phone: +39-02-252012-1  
Fax: +39-02-252012-65  
www.tungaloy.com/it

### Tungaloy Czech s.r.o.

Turanka 115  
CZ-627 00 Brno, Czech Republic  
Phone: +420-532 123 391  
Fax: +420-532 123 392  
www.tungaloy.com/cz

### Tungaloy Ibérica S.L.

C/Miquel Servet, 43B, Nau 7  
Pol. Ind. Bufalvent  
ES-08243 Manresa (BCN), Spain  
Phone: +34 93 113 1360  
Fax: +34 93 876 2798  
www.tungaloy.com/es

### Tungaloy Scandinavia AB

Bultgatan 38  
442 40 Kungälv, Sweden  
Phone: +46-462119200  
Fax: +46-462119207  
www.tungaloy.com/se

### Tungaloy Rus, LLC

Andropova avenue, h.18/7,  
11 floor, office 3, 115432,  
Moscow, Russia  
Phone: +7-499-683-01-80  
Fax: +7-499-683-01-81  
www.tungaloy.com/ru

### Tungaloy Polska Sp. z o.o.

Ul. Irysowa 1, 55-040 Bielany  
Wroclawskie, Poland  
Phone: +48 607 907 237  
www.tungaloy.com/pl

### Tungaloy U.K. Ltd

Gallan Park, Watling Street,  
Cannock, WS110XG, UK  
Phone: +44 121 4000 231  
Fax: +44 121 270 9694  
www.tungaloy.com/uk

### Tungaloy Hungary Kft

Erzsébet királyné útja 125  
H-1142 Budapest, Hungary  
Phone: +36 1 781-6846  
Fax: +36 1 781-6866  
www.tungaloy.com/hu

### Tungaloy Turkey

Serifali Mah.bayraktar Bulvari Kule Sk. No:26  
34775 Umraniye / Istanbul / Turkey  
Phone: +90 216 540 04 67  
Fax: +90 216 540 04 87  
www.tungaloy.com/tr

### Tungaloy Benelux b.v.

Tjalk 70  
NL-2411 NZ Bodegraven, Netherlands  
Phone: +31 172 630 420  
Fax: +31 172 630 429  
www.tungaloy.com/nl

### Tungaloy Croatia

Ulica bana Josipa Jelačića 87,  
10430, Samobor, Croatia  
Phone: +385 1 3326 604  
Fax: +385 1 3327 683  
www.tungaloy.com/hr

### Tungaloy Cutting Tool (Shanghai) Co.,Ltd.

Rm No 401 No.88 Zhabei  
Jiangchang No.3 Rd  
Shanghai 200436, China  
Phone: +86-21-3632-1880  
Fax: +86-21-3621-1918  
www.tungaloy.com/cn

### Tungaloy Cutting Tools (Taiwan) Co.,Ltd.

9F, No.293, Zhongyong Rd,  
Xinzhuan Dist, New Taipei City,  
24251 Taiwan  
Phone: +886-2-8521-9986  
Fax: +886-2-8521-8935  
www.tungaloy.com/tw

### Tungaloy Cutting Tools (Thailand) Co.,Ltd.

Interlink tower 4th Fl.  
1858/5-7 Bangna-Trad Road  
km.5 Bangna, Bangna, Bangkok 10260  
Thailand  
Phone: +66-2-751-5711  
Fax: +66-2-751-5715  
www.tungaloy.com/th

### Tungaloy Singapore (Pte.), Ltd.

62 Ubi Road 1, #06-11 Oxley BizHub 2  
Singapore 408734  
Phone: +65-6391-1833  
Fax: +65-6299-4557  
www.tungaloy.com/sg

### Tungaloy Vietnam

LE04.38, Lexington Residence  
67 Mai Chi Tho St., Dist. 2,  
Ho Chi Minh City, Vietnam  
Phone: +84-2837406660  
www.tungaloy.com/sg

### Tungaloy India Pvt. Ltd.

Indiabulls Finance Centre,  
Unit # 902-A, 9th Floor,  
Tower 1, Senapati Bapat Marg,  
Elphinstone Road (West),  
Mumbai-400013, India  
Phone: +91-22-6124-8804  
Fax: +91-22-6124-8899  
www.tungaloy.com/in

### Tungaloy Korea Co., Ltd

#1312, Byucksan Digital Valley 5-cha  
Beotkkot-ro 244, Geumcheon-gu  
153-788 Seoul, Korea  
Phone: +82-2-2621-6161  
Fax: +82-2-6393-8952  
www.tungaloy.com/kr

### Tungaloy Malaysia Sdn Bhd

50 K-2, Kelana Mall, Jalan SS6/14  
Kelana Jaya, 47301  
Petaling Jaya, Selangor Darul Ehsan  
Malaysia  
Phone: +603-7805-3222  
Fax: +603-7804-8563  
www.tungaloy.com/my

### Tungaloy Australia Pty Ltd

Unit 68 1470 Ferntree Gully Road  
Knoxfield 3180 Victoria, Australia  
Phone: +61-3-9755-8147  
Fax: +61-3-9755-6070  
www.tungaloy.com/au

### PT. Tungaloy Indonesia

Kompleks Grand Wisata Block AA-10 No.3-5  
Cibitung  
Bekasi 17510, Indonesia  
Phone: +62-21-8261-5808  
Fax: +62-21-8261-5809  
www.tungaloy.com/id



www.tungaloy.com

follow us at:

facebook.com/tungaloyjapan  
twitter.com/tungaloyjapan  
www.youtube.com/tungaloycorporation



AS9100 Certified  
78006  
2015.11.04  
ISO14001 Certified  
EC97J1123  
1997.11.26

Distributed by:



FIND US ON THE CLOUD!  
machingcloud.com

